

PHOTOGRAPHIC DETERMINATION OF THE ROTATIONAL STATE OF THE EYE USING MATRICES*

Ken Nakayama†
Smith-Kettlewell Institute
and Department of
Visual Sciences
Pacific Medical Center
San Francisco, California

ABSTRACT

A method is described which completely determines the rotational state of the eye in terms of three spherical angles or in terms of an axis of rotation and an extent of rotation. The experimental method consists of photographing two distinct markers on the globe through a telephoto lens. The data transformation relies on the fact that the rotation of a rigid body can be described by an orthogonal matrix and that the resultant rotation of successive rotations can be represented by the product of such matrices.

A number of recent studies have emphasized the importance of the kinematics of eye rotation in the understanding of the oculomotor control system. For example, kinematic considerations alone show that smooth pursuit movements are subserved by a different control mechanism than the eye positioning saccadic system.^{1,2} Another study has shown that the cat eye follows Listing's law when the animal is awake, but not when he is asleep,³ further emphasizing that the kinematic laws of eye rotation are behavioral laws determined by the central nervous system, and not simply the result of peripheral mechanical constraints. These studies prompt physiological and clinical questions, and it seems clear that a simple, accurate and reliable technique to completely specify the rotational state of the eye will be of increasing importance.

The experimental technique I describe is very simple and it can be used both for human and animal subjects. It consists of utilizing two available markers on the globe (episcleral vessels, limbal conjunctival vessels or natural pigmentation marks) or the placement of a pair

*Submitted December 27, 1973 for publication in the October, 1974 issue of the AMERICAN JOURNAL OF OPTOMETRY AND PHYSIOLOGICAL OPTICS.

†Research Associate, Ph.D.

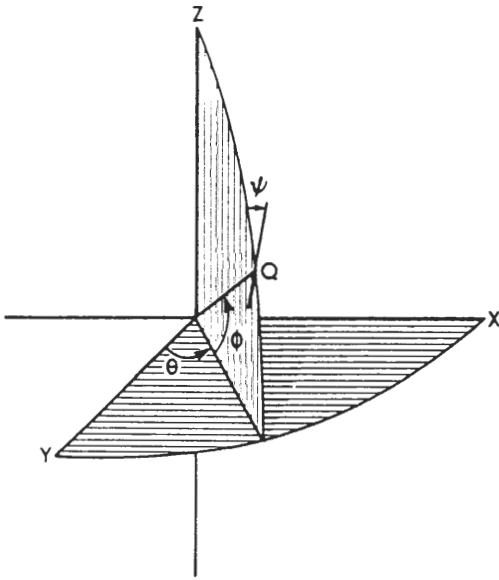

FIGURE 1: Coordinate system used in this discussion with pictorial description at angles Θ , Φ and Ψ . OQ is the line representing the direction regard. The positive Y axis represents the direction at regard when the eye is in the primary position.

of markers on the cornea. To avoid perspective distortion, the eye is photographed from a distance of over 50 centimeters from a direction corresponding to the primary position. The analysis requires an estimate of the center of rotation of the eye, the distance from the markers to this center, and the marker coordinates on the photographs when the eye is in the primary position. Furthermore, it is assumed that the distance of each marker to the center of rotation is the same.

Although this technique is not an on-line technique, I believe it has the potential of being on-line, or nearly so, with the use of a photoelectric flying spot scanning system and a small digital computer.

This paper confines itself to a description of the mathematical data transformation necessary to completely specify the rotational state of the eye from the position of the two marks on the photographs before and after a rotation. The transformation relies principally on the fact that the rotation of any rigid body can be

described by an orthogonal matrix, and that the resultant rotation of successive rotations can be expressed as a product of the matrices of the component rotations.⁴ A small programmable desk computer (Hewlett Packard 9820) was used to perform the transformation.

MATHEMATICAL ANALYSIS

I adopt a Fick type coordinate system described elsewhere.⁵ It is a left-handed system of axes for the left eye (Figure 1). The visual axis is coincident with the Y axis when the eye is in the primary position, the Z axis is the vertical axis positive upward, and the horizontal X axis is positive towards the ipsilateral temple. The origin is at the center of rotation of the eye. For clarification, I add that there are in reality two sets of X, Y, Z axes: one fixed in the head, designated X, Y, Z ; and the other fixed in the globe, designated X', Y', Z' . When the eye is in the primary position, these two sets of axes are coincident. All coordinates and axes unless specified will refer to the axes which are defined with respect to the head.

Any eye position can be described completely by three spherical angles (often referred to as Euler angles); following Robinson,⁵ I define an angle Θ which makes a right-handed rotation about the globe Z' axis, an angle Φ which defines a left-handed rotation about the globe X' axis, and an angle Ψ which defines a left-handed rotation about the globe Y' axis (Figure 1).

The x, y, z coordinates of any globe marker can be experimentally determined from the photographs by noting the fact that if the entrance pupil of the camera is sufficiently far from the eye, the locus of globe markers is projected onto the film of the camera as a plane parallel or orthographic projection. Thus the horizontal and vertical distances on the photographs are linearly related to the x and z distances. The y coordinate can be determined from the following expression

$$y = \sqrt{1 - (x^2 + z^2)} \tag{1}$$

where the values x and z are scaled such that

the distance from marker to the center of rotation is equal to 1. This distance can be estimated from a schematic eye, or it can be determined by having the subject make eye deviations of known eccentricity, and noting changes in the position of the globe marks on the photographs.

In order to completely determine the rotational state of the eye in terms of three independent parameters such as the three spherical angles described above, I rely on the fact that the change of position of a body point under a rigid body rotation can be expressed as a matrix multiplication:

$$R \begin{pmatrix} x \\ y \\ z \end{pmatrix} = \begin{pmatrix} x' \\ y' \\ z' \end{pmatrix} \quad (2)$$

$$\begin{pmatrix} x'_1 \\ y'_1 \\ z'_1 \end{pmatrix} = R \begin{pmatrix} x_1 \\ y_1 \\ z_1 \end{pmatrix} \quad (3a)$$

$$\begin{pmatrix} x'_2 \\ y'_2 \\ z'_2 \end{pmatrix} = R \begin{pmatrix} x_2 \\ y_2 \\ z_2 \end{pmatrix} \quad (3b)$$

If I can find this R matrix, I will be able to describe the rotation in terms of Θ , Φ and Ψ , since any rotation matrix can be written in terms of three Euler angles. For example, the R matrix, designated by nine coefficients, is:

$$R = \begin{pmatrix} R_{11} & R_{12} & R_{13} \\ R_{21} & R_{22} & R_{23} \\ R_{31} & R_{32} & R_{33} \end{pmatrix} \quad (4a)$$

These coefficients can be expressed in terms of three spherical angles as follows (see Appendix for derivation):

$$R = \begin{pmatrix} \cos \Theta \cos \Psi + \sin \Theta \sin \Phi \sin \Psi & \cos \Phi \sin \Theta & \sin \Psi \cos \Theta - \sin \Theta \sin \Phi \cos \Psi \\ \sin \Psi \sin \Phi \cos \Theta - \sin \Theta \cos \Psi & \cos \Phi \cos \Theta & -\sin \Psi \sin \Theta - \cos \Theta \cos \Psi \sin \Phi \\ \sin \Psi \cos \Phi & \sin \Phi & \cos \Psi \cos \Phi \end{pmatrix} \quad (4b)$$

In the above equation x, y, z and x', y', z' are the coordinates of any point on the rigid body before and after the rotation, respectively. R is a 3 x 3 orthogonal matrix.⁴

Now consider the pair of points P_1 and P_2 which are located on the surface of the globe when the eye is in the primary position. P_1 and P_2 have the coordinates (x_1, y_1, z_1) and (x_2, y_2, z_2) respectively. The set of coordinates of the point is also called a position vector.

Now if the globe moves through any particular rotation with angles Θ, Φ and Ψ , the points P_1 and P_2 will move to new positions which I shall call P'_1 and P'_2 with coordinates (x'_1, y'_1, z'_1) and (x'_2, y'_2, z'_2) (see Figure 2).

Given the position vectors of P_1 and P_2 before and after the rotation, there exists a single rotation matrix R which will take both points, P_1 and P_2 , to their final positions, P'_1 and P'_2 respectively.

If I can determine the nine coefficients of the rotation matrix R, I can obtain the values of Θ, Φ and Ψ from Equation 4a and 4b, since all terms of the matrix can be expressed in terms of Θ, Φ and Ψ .

$$\Phi = \sin^{-1} R_{32} \quad (5a)$$

$$\Theta = \sin^{-1} \left(\frac{R_{12}}{\cos \Phi} \right) \quad (5b)$$

$$\Psi = \sin^{-1} \left(\frac{-R_{31}}{\cos \Phi} \right) \quad (5c)$$

Therefore the task is to find the R matrix. In practice it is difficult to deal directly with the Equations 5a, 5b, and 5c to get the angles Θ, Φ, Ψ and the R matrix, as these require the solution of simultaneous nonlinear equations.

In order to simplify the problem further, it is convenient to rotate the axes of the head based coordinate system, so that one of the points P_1 has the coordinates (0, 1, 0). I do this

by rotating the head axes by a right-handed rotation through angle alpha (α) about Z and a left-handed rotation through angle beta (β) about X', with

$$\alpha = \tan^{-1} \left(\frac{x_1}{y_1} \right) \tag{6}$$

$$\beta = \sin^{-1} \left(\frac{z_1}{(x_1^2 + y_1^2 + z_1^2)^{1/2}} \right) \tag{7}$$

I call this new head based coordinate system A, B, C. In order to express all points P_1, P_2, P_1' and P_2' in terms of the new A, B, C set of axes, I need to multiply the coordinates of each marker or position vector by a matrix T, where:

$$T = \begin{pmatrix} \cos \alpha & -\sin \alpha & 0 \\ \sin \alpha \cos \beta & \cos \alpha \cos \beta & \sin \beta \\ -\sin \alpha \sin \beta & -\cos \alpha \sin \beta & \cos \beta \end{pmatrix} \tag{8}$$

Therefore T transforms each position vector described in terms of X, Y, Z into the new coordinates A, B, C:

$$T \begin{pmatrix} x_1 \\ y_1 \\ z_1 \end{pmatrix} = \begin{pmatrix} a_1 \\ b_1 \\ c_1 \end{pmatrix} = \begin{pmatrix} 0 \\ 1 \\ 0 \end{pmatrix} \tag{9}$$

$$T \begin{pmatrix} x_2 \\ y_2 \\ z_2 \end{pmatrix} = \begin{pmatrix} a_2 \\ b_2 \\ c_2 \end{pmatrix} \tag{10}$$

$$T \begin{pmatrix} x_1' \\ y_1' \\ z_1' \end{pmatrix} = \begin{pmatrix} a_1' \\ b_1' \\ c_1' \end{pmatrix} \tag{10}$$

$$T \begin{pmatrix} x_2' \\ y_2' \\ z_2' \end{pmatrix} = \begin{pmatrix} a_2' \\ b_2' \\ c_2' \end{pmatrix} \tag{10}$$

Working in this new A, B, C system, I am faced with the problem of finding a rotation matrix R' which will transform vectors $(a_1 b_1 c_1)$ to $(a_1' b_1' c_1')$ and $(a_2 b_2 c_2)$ to $(a_2' b_2' c_2')$. The problem is easily soluble since one of the vectors, namely $(a_1 b_1 c_1)$ is in the simple form of (0,1,0). For matrix R' I define three angles analogous to our desired Θ, Φ and Ψ and call them Θ', Φ', Ψ' . The rotation of the two points in this new A, B, C coordinate system can be expressed algebraically as:

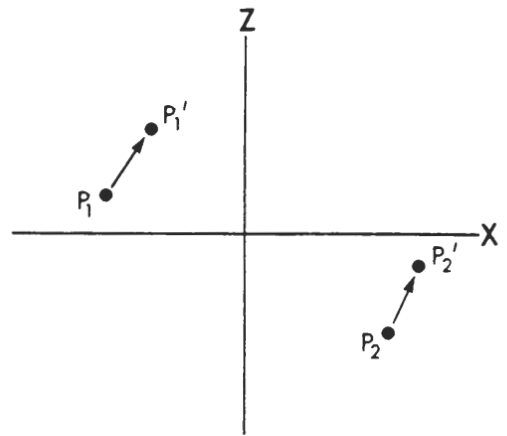

FIGURE 2: Schematic representation of photographs of eye markers P_1 and P_2 when the eye is in the primary position. P_1' and P_2' refer to the markers when the eye is in a particular tertiary position. A single rotation matrix R will take P_1 to P_1' and P_2 to P_2' .

$$\begin{pmatrix} R'_{11} & R'_{12} & R'_{13} \\ R'_{21} & R'_{22} & R'_{23} \\ R'_{31} & R'_{32} & R'_{33} \end{pmatrix} \begin{pmatrix} 0 \\ 1 \\ 0 \end{pmatrix} = \begin{pmatrix} a_1' \\ b_1' \\ c_1' \end{pmatrix} \tag{11}$$

$$\begin{pmatrix} R'_{11} & R'_{12} & R'_{13} \\ R'_{21} & R'_{22} & R'_{23} \\ R'_{31} & R'_{32} & R'_{33} \end{pmatrix} \begin{pmatrix} a_2 \\ b_2 \\ c_2 \end{pmatrix} = \begin{pmatrix} a_2' \\ b_2' \\ c_2' \end{pmatrix} \tag{12}$$

To determine expressions for the coefficients of the R' matrix, refer to Equation 4b, substituting R' for R and Θ', Φ' and Ψ' for Θ, Φ and Ψ , respectively.

I can now solve for angles Θ', Φ' and Ψ' by selecting particular equations contained in Equations (11) and (12). Specifically from the third row of (11), R'_{32} is the only relevant term since the other two coefficients are multiplied by zero, so:

$$\begin{aligned} R'_{32} &= c_1' \\ \sin \Phi' &= c_1' \\ \Phi' &= \sin^{-1} c_1' \end{aligned} \tag{13}$$

Knowing Φ' I can find Θ' from top row equation in (11) since:

$$\begin{aligned} R'_{12} &= a_1' \\ \sin \Theta' \cos \Phi' &= a_1' \\ \Theta' &= \sin^{-1} \left[\frac{a_1'}{\cos \Phi'} \right] \end{aligned} \tag{14}$$

Since I know Φ' and Θ' , I use the information from the third row equation in (12) to find Ψ' . Thus:

$$-a_2 \sin \Psi' \cos \Phi' + b_2 \sin \Phi' + c_2 \cos \Psi' \cos \Phi' = c_2' \tag{15a}$$

$$\cos \Psi' c_2 - \sin \Psi' a_2 = k \tag{15b}$$

where $k = \frac{c_2' - \sin \Phi' b_2}{\cos \Phi'}$.

$$\begin{pmatrix} R_{11} & R_{12} & R_{13} \\ R_{21} & R_{22} & R_{23} \\ R_{31} & R_{32} & R_{33} \end{pmatrix} = \begin{pmatrix} T_{11} & T_{21} & T_{31} \\ T_{12} & T_{22} & T_{32} \\ T_{13} & T_{23} & T_{33} \end{pmatrix} \begin{pmatrix} R'_{11} & R'_{12} & R'_{13} \\ R'_{21} & R'_{22} & R'_{23} \\ R'_{31} & R'_{32} & R'_{33} \end{pmatrix} \begin{pmatrix} T_{11} & T_{12} & T_{13} \\ T_{21} & T_{22} & T_{23} \\ T_{31} & T_{32} & T_{33} \end{pmatrix} \tag{20}$$

by noting that the three successive rotations also take the points P_1 and P_2 to P_1' and P_2' , respectively. Since the matrix of a single rotation is equivalent to the product of the matrices of the component rotations,⁴ the nine coefficients of the R matrix can be obtained simply by multiplying the matrices corresponding to the component rotations. Thus:

$$R = T^{-1} R' T \tag{19}$$

or

$$\begin{pmatrix} R_{11} & R_{12} & R_{13} \\ R_{21} & R_{22} & R_{23} \\ R_{31} & R_{32} & R_{33} \end{pmatrix} = \begin{pmatrix} T_{11} & T_{21} & T_{31} \\ T_{12} & T_{22} & T_{32} \\ T_{13} & T_{23} & T_{33} \end{pmatrix} \begin{pmatrix} R'_{11} & R'_{12} & R'_{13} \\ R'_{21} & R'_{22} & R'_{23} \\ R'_{31} & R'_{32} & R'_{33} \end{pmatrix} \begin{pmatrix} T_{11} & T_{12} & T_{13} \\ T_{21} & T_{22} & T_{23} \\ T_{31} & T_{32} & T_{33} \end{pmatrix} \tag{20}$$

Then the trigometric equation (15b) can be put in the form of a quadratic, with the solution:

$$x = \sin \Psi' = \frac{-b \pm \sqrt{b^2 - 4ac}}{2a} \tag{16}$$

where: $a = a_2^2 + c_2^2$ (17a)

$b = 2a_2 k$ (17b)

$c = k^2 - c_2^2$ (17c)

The equation has two roots and thus Ψ' has two possible values. The meaningful value of Ψ' can be determined by substituting the values for Θ' , Φ' and each particular Ψ' in the first row equation of (12). Thus:

$$\begin{aligned} &\cos \Psi' \cos \Theta' a_2 + \sin \Theta' \sin \Phi' \sin \Psi' a_2 + \\ &\cos \Phi' \sin \Theta' b_2 + \sin \Psi' \cos \Theta' c_2 - \\ &\sin \Theta' \cos \Psi' \sin \Phi' c_2 = a_2' \end{aligned} \tag{18}$$

The value of Ψ' coming from (16) which best predicts the value of a_2' in Equation (18) is chosen as the proper value.

Now given Θ' , Φ' and Ψ' I can obtain all the coefficients of the R' matrix, using the evaluation of all the coefficients in terms of Θ , Φ and Ψ in Equation 4b.

Now consider the series of successive rotations represented by T then R' and then T⁻¹, where T⁻¹ is the inverse of T. The composite of these three rotations will be equivalent to the single rotation R, and this can be seen most clearly,

Note that T⁻¹ is the transpose of T, since the inverse of an orthogonal matrix is its transpose. Now that I have the coefficients of the R matrix from Equation 20, the angles Θ , Φ and Ψ can be easily determined from the Equations 5a, 5b and 5c.

AXIS AND EXTENT OF ROTATION

Instead of expressing the rotational state of the eye in terms of three spherical angles, it may also be useful to express the position of the globe in terms of a single rotation from the primary position. This description is in terms of an axis of rotation and a magnitude of a single rotation which takes the globe from primary to the particular gaze position. Any rotational state of the globe can be described in this manner, and it should be noted in particular that if Listing's Law is true for a particular eye, all such axes must lie in a plane.⁶

To determine the axis of rotation, I rely on the fact that all points lying on the axis of rotation are unchanged by the rotation. Therefore there exists a set of position vectors along the axis (also called eigen vectors) which remain invariant under the rotation transformation. Therefore:

$$\begin{pmatrix} R_{11} & R_{12} & R_{13} \\ R_{21} & R_{22} & R_{23} \\ R_{31} & R_{32} & R_{33} \end{pmatrix} \begin{pmatrix} x \\ y \\ z \end{pmatrix} = \begin{pmatrix} x \\ y \\ z \end{pmatrix} \text{ or } \tag{21}$$

$$\begin{aligned} (R_{11}-1)x + R_{12}y + R_{13}z &= 0 \\ R_{21}x + (R_{22}-1)y + R_{23}z &= 0 \\ R_{31}x + R_{32}y + (R_{33}-1)z &= 0. \end{aligned} \tag{22}$$

The above set of homogenous linear equations cannot furnish definite values of x,y,z but only their relative ratios. However, I am interested only in the orientation of the axis of rotation in space, and these ratios completely specify the axis of rotation being direction numbers specifying the line.⁷ Usually the most convenient method of specifying a line such as an axis, is to specify the components of that line were it a vector of unit length and these components are termed the direction cosines of the line. Therefore, I can find a particular set x,y,z which satisfies the expression

$$\sqrt{x^2 + y^2 + z^2} = 1. \tag{23}$$

These particular values which satisfy Equation 22 are called the direction cosines of the axis of rotation, λ , μ and ν , respectively.

In order to find the extent of the rotation, I first consider any unit vector perpendicular to the axis of rotation and call this vector (a,b,c). To be perpendicular to the axis of rotation, the dot product of this vector and the unit axis vector must be zero. Thus,

$$\lambda a + \mu b + \nu c = 0. \tag{24}$$

If I multiply this perpendicular unit vector (a,b,c) by the rotation matrix R which I found earlier, I define a new vector:

$$\begin{pmatrix} a' \\ b' \\ c' \end{pmatrix} = R \begin{pmatrix} a \\ b \\ c \end{pmatrix} \tag{25}$$

Since the angle made by a line perpendicular to an axis at rotation is equivalent to the magnitude of a rotation, the angle W between position vectors (a,b,c) and (a'b'c') is the magnitude of the rotation. The cosine of this angle W is equal to the dot product of this unit vector before and after the rotation. Thus:

$$W = \cos^{-1} [aa' + bb' + cc']. \tag{26}$$

ACKNOWLEDGMENTS

I thank Mr. Joseph Schlessinger, Mr. Roland Herman and Dr. Duane Hockensmith for valuable suggestions.

This investigation was supported by NIH research grant No. PO1 EY-00299 from the National Eye Institute and the Smith-Kettlewell Eye Research Foundation.

REFERENCES

1. Westheimer, G., Saccadic eye movements, in the Oculomotor System and Brain Functions, edited by V. Zikmund. Bratislava, Czechoslovakia, Publishing House of the Slovak Academy of Sciences, 1973, pp. 57-77.
2. Westheimer, Gerald and Suzanne P. McKee, Failure of Donders' Law during smooth pursuit eye movements, *Vision Res.*, 13 (12): 2145-2153, 1973.
3. Nakayama, K., Cat eye muscle coordination in waking and sleeping; Paper presented to Association for Research in Vision and Ophthalmology, Annual meeting 1973.
4. Goldstein, Herbert, *Classical Mechanics*. Cambridge, Mass., Addison-Wesley, 1953, Ch.4.
5. Robinson, D. A., A method of measuring eye movement using a scleral search coil in a magnetic field, *IEEE Trans. on Bio-med. Electronics BME-10*: 137-145, 1963.
6. Westheimer, Gerald, *Kinematics of the eye*, *J. Opt. Soc. Am.*, 47 (10): 967-974, 1957.
7. Oakley, C. O., *Analytic Geometry*. New York, Barnes and Noble, 1954, Ch.18.

AUTHOR'S ADDRESS:

Dr. Ken Nakayama
 Smith-Kettlewell Institute and
 Department of Visual Sciences
 Pacific Medical Center
 2232 Webster Street
 San Francisco, California 94115

APPENDIX:
 DERIVATION
 OF THE R MATRIX

The R matrix represents the resultant of three rotations about the three globe axes. Each individual rotation can be considered as a simple two-dimensional rotation, since any rotation about an axis always leaves the coordinates of that axis unchanged. The rotation matrices corresponding to Θ , Φ and Ψ are

$$R_{\Theta} = \begin{pmatrix} \cos \Theta & \sin \Theta & 0 \\ -\sin \Theta & \cos \Theta & 0 \\ 0 & 0 & 1 \end{pmatrix} \quad (A1)$$

$$R_{\Phi} = \begin{pmatrix} 1 & 0 & 0 \\ 0 & \cos \Phi & -\sin \Phi \\ 0 & \sin \Phi & \cos \Phi \end{pmatrix} \quad (A2)$$

and

$$R_{\Psi} = \begin{pmatrix} \cos \Psi & 0 & \sin \Psi \\ 0 & 1 & 0 \\ -\sin \Psi & 0 & \cos \Psi \end{pmatrix} \quad (A3)$$

Any rotation can be described by a matrix, and the resultant rotation of successive rotations is also a matrix.⁴ Furthermore, the matrix corresponding to a resultant rotation is equal to the product of its component matrices. Therefore:

$$R = R_{\Theta} R_{\Phi} R_{\Psi} \quad (A4)$$

which gives me the coefficients of the R matrix in terms of Θ , Φ and Ψ , which is described in Equation 4b.